

PREFERRED ENGINEERING

automated heavy lifting

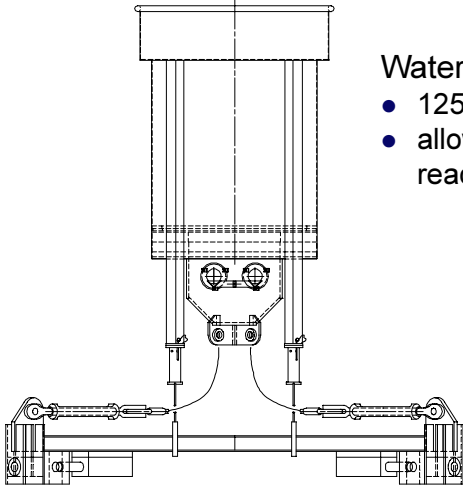

Watertight Hook Box

- 125 ton capacity
- allows flooded lift of reactor internals



**Dryer/Separator
Lifting Strongback**

**RPV Head Carosel
Lifting Strongback**

- stud handling
- nut runners

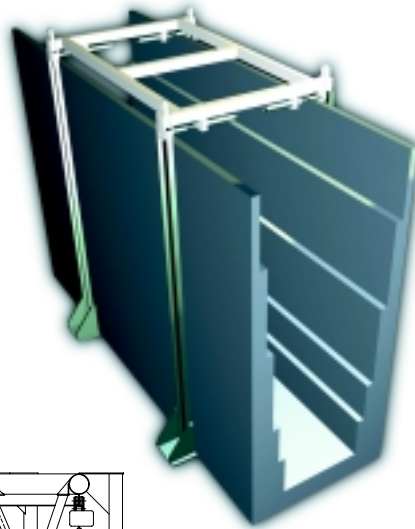
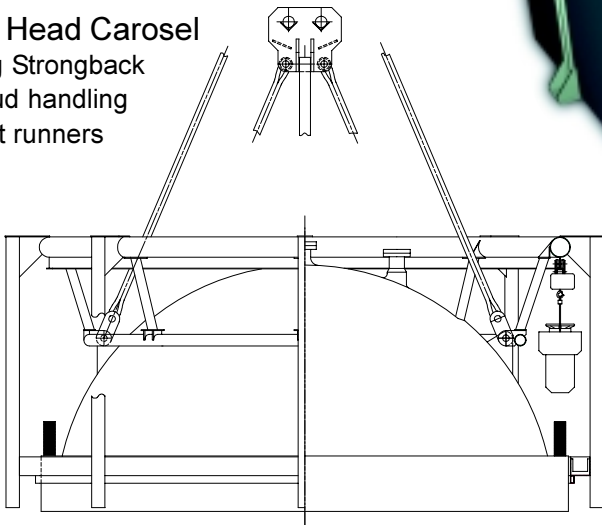

**Cattle Chute
Lifting Strongback**

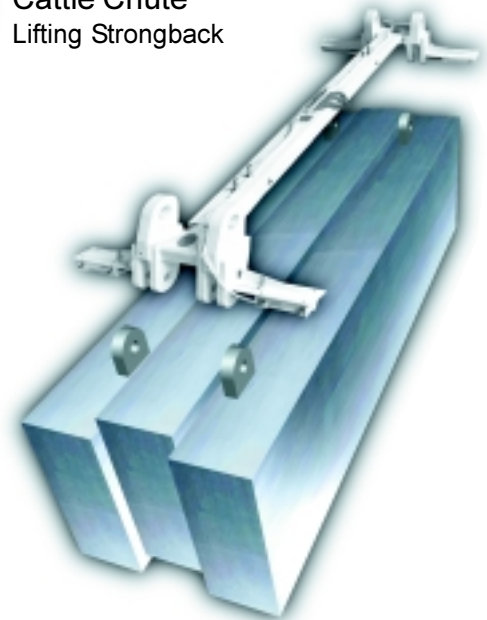

**Shield Block
Lifting Strongback**

- 40-60 tons

Features

- Designed/Tested NUREG O612/ANSI N 14.6
- Remote strongback engagement (wet or dry)

Benefits

- Reduced personnel exposure
- Improved critical path schedule

PREFERRED ENGINEERING

a subsidiary of Preferred Utilities Mfg. Corp.
 31-35 South St. • Danbury • CT • 06810
 phone: (203)743-6741 • fax: (203) 798-7313
 peinfo@preferred-mfg.com • <http://www.preferred-mfg.com>