

SERVO ACTUATOR

Model UM

- 90° rotary electric actuator
- 72, 140, 280, 430 or 720 ft-lb. torque output
- Designed for modulation service
- Self-locking drive system to hold in last position
- Electrically isolated feedback potentiometer provides indication of shaft position
- Two (2) auxiliary limit switch position output

Description

The Model UM Servo Actuator provides directly connected and precise modulating control of fuel valves and combustion air and flue gas control dampers. The actuator opens, modulates, and closes the valves and/ or dampers in accordance with the integrated combustion control and burner management system programs. An integral interlock switch provides proof of open or closed position for safe burner operation. In addition, the feedback potentiometer provides indication of the motor's shaft position. The UM Actuator is used on boiler control applications that have a maximum of 720 ft-lbs torque required. For heavier equipment service – consult the factory.

Operation

The Model UM Actuator uses an instantly reversible motor to rotate a stainless steel output shaft through a reduction of precision worm gears. The output shaft actuates four adjustable cam operated switches: two (2) travel limit switches to stop motor operation at pre-selected positions and two (2) auxiliary switches to provide valve and damper position proving interlocks. The actuator incorporates 'Built-in Motor Design', by which the stator of motor is directly inserted into the body housing, which works as a heat sink – efficiently radiating motor heat to atmosphere therefore the actuator can be stopped, started, or instantly reversed at any time within its travel without overheating or loss of power. For maximum durability, all the major parts of the actuator are lubricated with long life molybdenum disulfide grease (MOS2) at assembly therefore re-lubrication is in principle not required.

Suggested Specification

Provide a separate direct acting Servo Actuator for the fuel gas and fuel oil flow control valves and the combustion air damper. The servo actuator shall modulate the fuel valves without the use of linkage. The actuator shall be totally enclosed in a dust-tight, splash-proof housing, have two (2) integral, snap-action, travel limit proving switches, electrically isolated shaft position feedback potentiometer, 90° rotation in 30 seconds and maintenance-free motor and gear train. The actuator shall be capable of being stopped, started, or instantly reversed without loss of power or overloading. The actuator shall be a Preferred Instruments, Danbury, CT, Model UM-xxx ['xxx' = 072, 140, 280, 430 or 720 rated torque in ft-lbs].

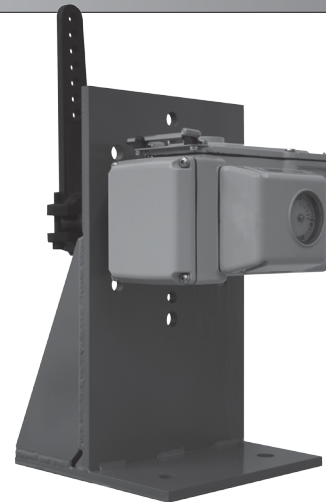

Model UM Servo Actuator with Floor Stand

Specifications:

Power:	120 VAC - 50 / 60 Hz UM-072 20VA UM-140 30VA UM-250 90VA UM-430 95VA UM-720 100VA
Ambient Temperature:	-13° F to 131° F (-25° C to + 55° C)
Input:	Switching SPDT or floating contacts
Torque:	72, 140, 280, 430 or 720 ft-lbs (depending on model selected)
Duty cycle:	100%
Rotation:	90° in 30 seconds
Feedback Potentiometer:	1000 ohm
Auxiliary Switch:	Two (2) Integral SPDT, adjustable
Installation Position:	Any
Output Shaft:	Stainless Steel (SUS303)
Motor:	Reversible, split phase, capacitor type, oil submerged
Enclosure:	UM-072, 140, 280, 430 & UM-720: NEMA 4/4X Watertight
Manual Operation:	Detachable Crank Handle
Ordering Information:	1. UM-[072, 140, 280, 430 or 720] Specify 72, 140, 280, 430 or 720 nominal torque rating 2. Consult Factory for mating valves and mounting options.

SERVO ACTUATOR

Model UM

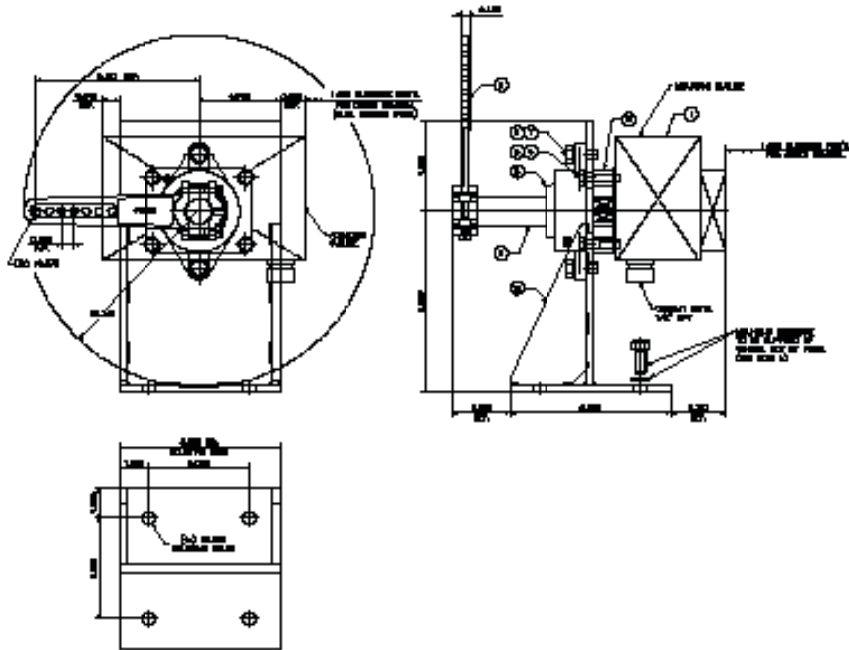

Catalog Number	Description
120 VAC Triac Control Signal Input	
UM-072-FS	Actuator, 72 Ft Lbs Torque, 90° / 25 Seconds, 1K Potentiometer 0.591" Square Shaft, (2) SPST Auxiliary Switches, Floor Stand
UM-140-FS	Actuator, 140 Ft Lbs Torque, 90° / 25 Seconds, 1K Potentiometer 0.906" Square Shaft, (2) SPST Auxiliary Switches, Floor Stand
UM-280-FS	Actuator, 280 Ft Lbs Torque, 90° / 25 Seconds, 1K Potentiometer 0.906" Square Shaft, (2) SPST Auxiliary Switches, Floor Stand
UM-430-FS	Actuator, 430 Ft Lbs Torque, 90° / 25 Seconds, 1K Potentiometer 1.182" Square Shaft, (2) SPST Auxiliary Switches, Floor Stand
UM-720-FS	Actuator, 720 Ft Lbs Torque, 90° / 25 Seconds, 1K Potentiometer 1.182" Square Shaft, (2) SPST Auxiliary Switches, Floor Stand
4-20 mADC Control Signal Input / Feedback Output	
UMP-072-FS	Actuator, 72 Ft Lbs Torque, 90° / 25 Seconds, 1K Potentiometer 0.591" Square Shaft, (2) SPST Auxiliary Switches, Floor Stand
UMP-140-FS	Actuator, 140 Ft Lbs Torque, 90° / 25 Seconds, 1K Potentiometer 0.906" Square Shaft, (2) SPST Auxiliary Switches, Floor Stand
UMP-280-FS	Actuator, 280 Ft Lbs Torque, 90° / 25 Seconds, 1K Potentiometer 0.906" Square Shaft, (2) SPST Auxiliary Switches, Floor Stand
UMP-430-FS	Actuator, 430 Ft Lbs Torque, 90° / 25 Seconds, 1K Potentiometer 1.182" Square Shaft, (2) SPST Auxiliary Switches, Floor Stand
UMP-720-FS	Actuator, 720 Ft Lbs Torque, 90° / 25 Seconds, 1K Potentiometer 1.182" Square Shaft, (2) SPST Auxiliary Switches, Floor Stand
Model UM Optional Hardware	
107372	Pipe Linkage Kit, 1" NPT with Ball and Socket
107373	Pipe Linkage Kit, 1½" NPT with Ball and Socket
20054	Damper Lever Arm